

0.4

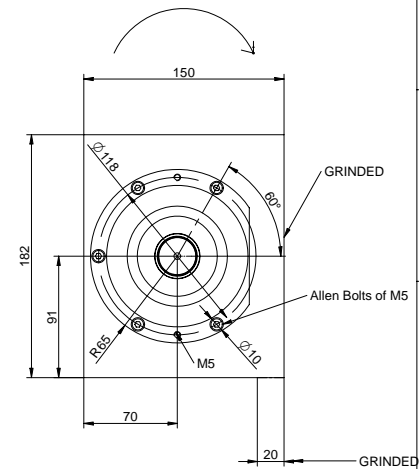

The spindle must be rotating when the cooling start.

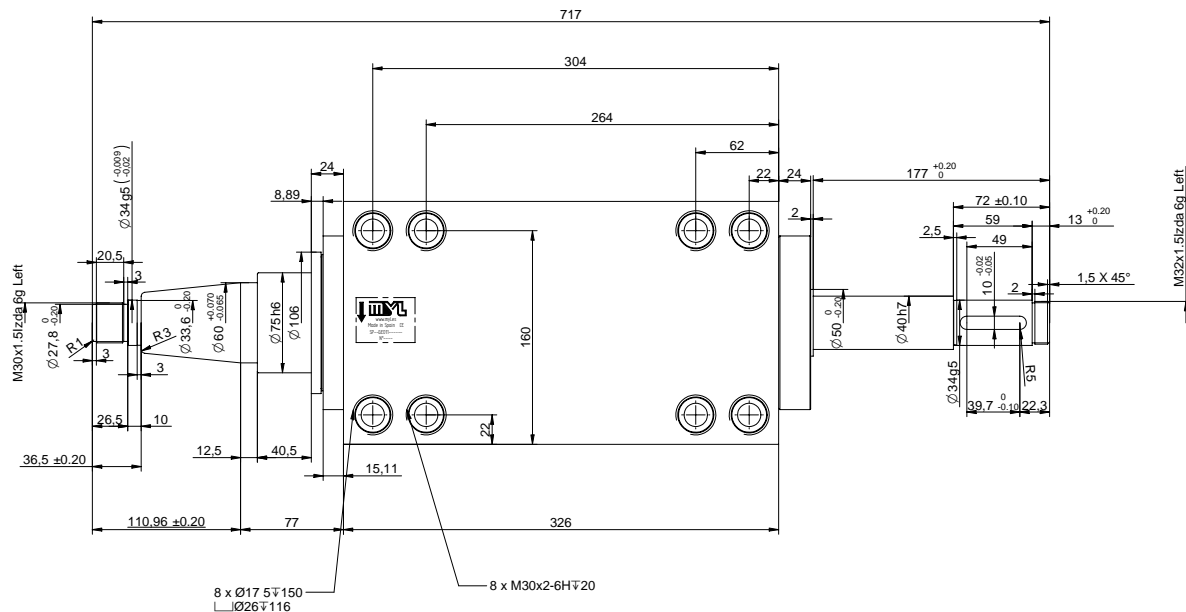
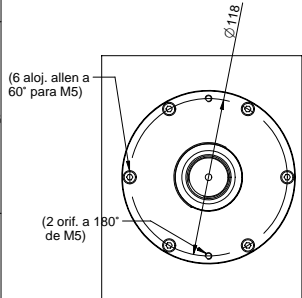
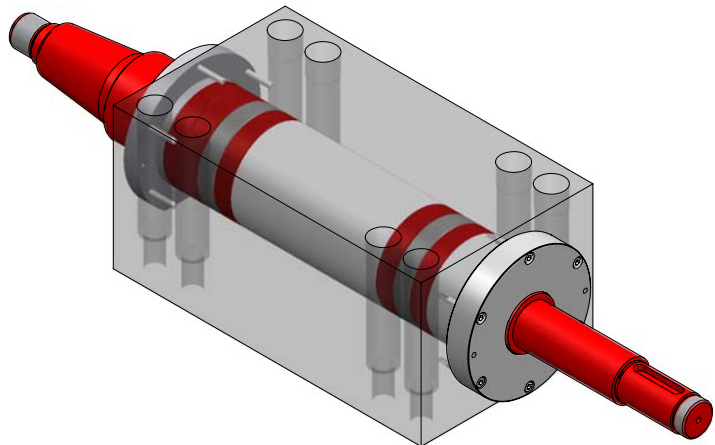
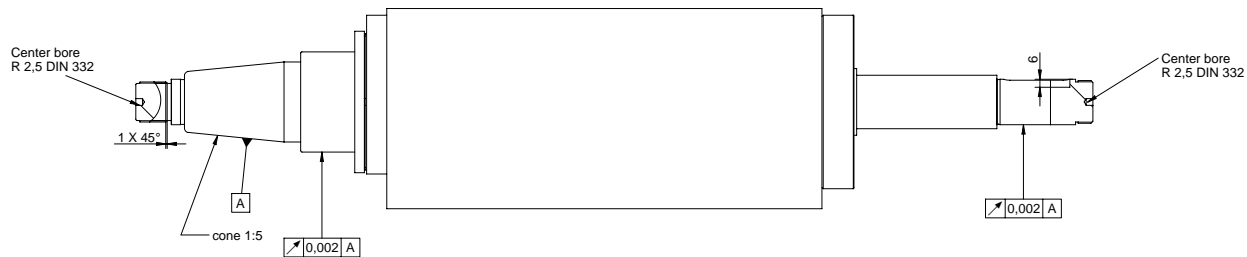

SPINDLE CHARACTERISTICS	
TYPE	
ROTATION HAND	Left
TAPER TYPE	ext Ø60
RPM MAX.	2.800 r.p.m.
LUBRIFICACIÓN	Grease
TOTAL WEIGHT	73 Kg.
WORKING POSIT.	HORIZONTAL

REV.	MODIFICACIÓN	FECHA	AUTOR	ELABORADO	REVISADO	APROBADO	REVISOR
01	Montaje 3TDT	03/09/2008	IL				
DIBUJADO				Ibon	COMPROBADO	Ibon	FECHA
MATERIAL				N/A	DIMENSIONES		06.11.2007
DUREZA					TRATAMIENTO		66.233
DESCRIPCIÓN				CF 060 L.326 I S	ESCALA	1:1.33	PLANO Nº SP21GEO11000002
							000.WEIO 9001507182



www.myl.es

PLANO A1H