

Conicidad 1/7.5

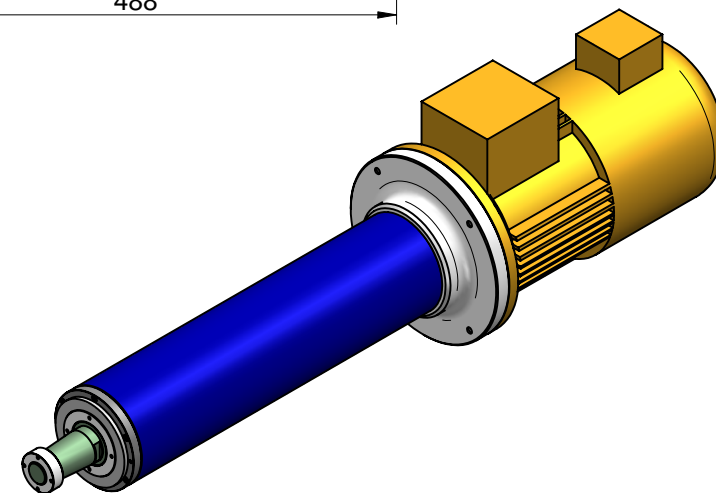
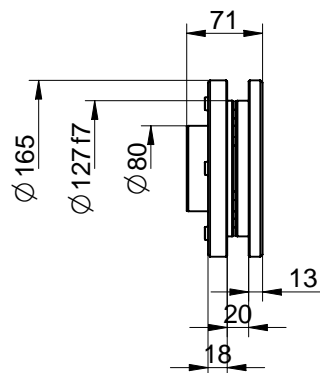
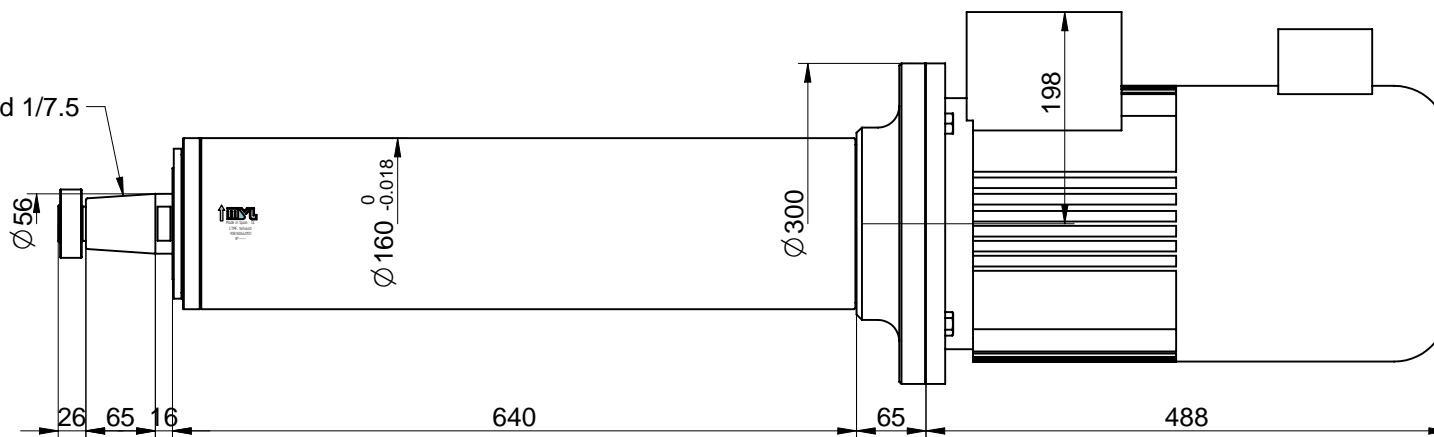

### CARACTERISTICAS HUSILLO

MODELO	CTMF 160x640
SENTIDO DE GIRO	Derecha
SALIDA AMARRE	Cono $\phi 56$ de 1/7.5
VELOCIDAD MAX.	5.000 r.p.m.
LUBRIFICACIÓN	Grasa
PESO	150 KGR.
POSI. TRABAJO	Vertical

### CARACTERISTICAS MOTOR

MODELO	145250110005 - F132
POTENCIA	11 KW
RPM	5.000 RPM
TENSION	400 V
INTENSIDAD	19.4 A
FRECUENCIA	167 Hz
Nº DE POLOS	

Independet fan 220-380 V

### Talleres MYL,s.a.

Dibujado	Ainara		26-04-06		
Comprobado	Xabi		11-09-06		
Material	Dimensiones				
Peso Bruto	Peso pieza	Tratamiento	Dureza	Escala	Piezas/Maquina
	126.31 Kg.			1:7.7	
Maquina/Husillo	CTMF 160X640		Plano No	908160640101	
Grupo			Sustituye		
Denominacion	CONJUNTO				

Nº DE SERIE	SALTO DELANTERO	SALTO TRASERO	CONO FRONTAL	REALIZADO
TOLERANCIAS NO ESPECIFICADAS PARA PIEZAS MECANIZADAS				
TOLERAN. GENER. DI N7168 DE FERENCIAS SUPERIOR/INFERIOR				
LONGITUDINALES	REDONDEOS-BISELES	ANGULARES (LADO CORTO)		
0.5- 6	*0.1	0.5- 3	*0.2	0- 10
6- 30	*0.2	3- 6	*0.5	10- 50
30- 120	*0.3	6- 30	*1	50- 120
120- 400	*0.5	30- 120	*2	120- 400
400-1000	*0.8	120- 400	*4	> 400
1000-2000	*1.2	ESQUINAS SIN INDICACION CHAFLAN 0.2x45°		

## ELECTRIC CONNECTIONS FOR THE FAN

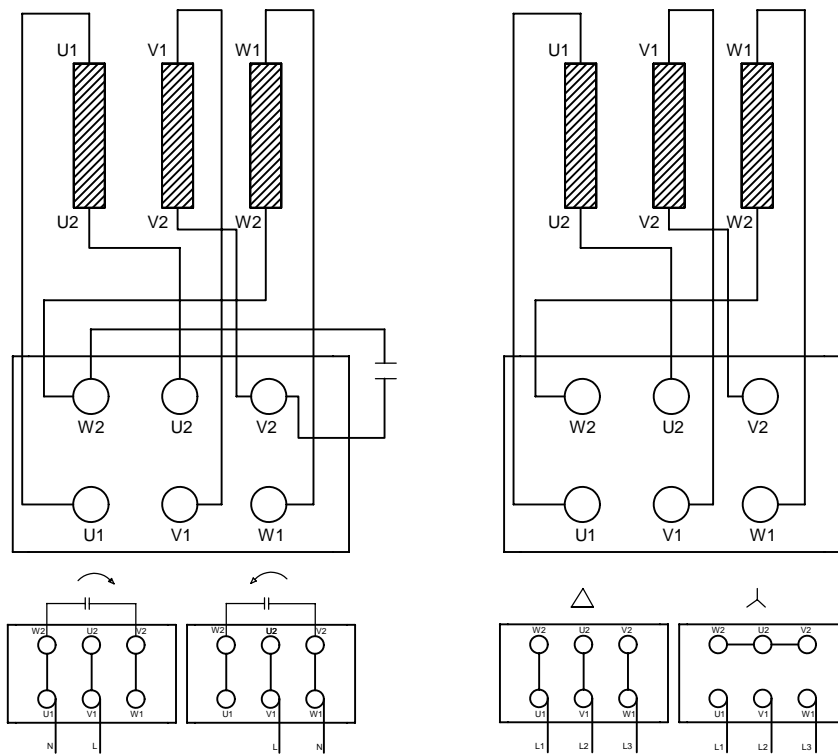

FBI-Bg 132 RBK  
 U1=50Hz 230-303 VD/400-525 VY I1: 0,64/0,37 A  
 U2=60Hz 230-333 VD/400-575 VY I2:0,57/0,32 A  
 rpm1:2619 rpm2:2986 cos:0,72 m3/h:515

Motors: 55610209 VDE 0530:CI

## ELECTRIC CONNECTIONS FOR THE MOTOR UNIT

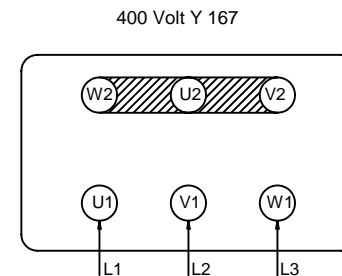

Nº DE SERIE	SALTO DELANTERO	SALTO TRASERO	CONO FRONTAL	REALIZADO
TOLERANCIAS NO ESPECIFICADAS PARA PIEZAS MECANIZADAS				
TOLERAN. GENER. DI N7168 DE FERENCIAS SUPERIOR/INFERIOR				
LONGITUDINALES	REDONDEOS-BISELES	ANGULARES (LADO CORTO)		
0.5- 6	*0.1	0.5- 3	*0.2	0- 10 *1
6- 30	*0.2	3- 6	*0.5	10- 50 *30'
30- 120	*0.3	6- 30	*1	50- 120 *20'
120- 400	*0.5	30- 120	*2	120- 400
400-1000	*0.8	120- 400	*4	> 400 *5'
1000-2000	*1.2	ESQUINAS SIN INDICACION CHAFLAN 0.2x45°		

### Talleres MYL,s.a.

Dibujado	Ainara		26-04-06		
Comprobado	Xabi		11-09-06		
Material		Dimensiones			
Peso Bruto	Peso pieza	Tratamiento	Dureza	Escala	Piezas/Maquina
	126.31 Kg.			1:7.7	
Maquina/Husillo	CTMF 160X640		Plano No	908160640101	
Grupo			Sustituye		
Denominacion	CONJUNTO				